

# **SLING SHOT** Pat Pend



*Finally  
a  
race  
proven,  
light  
weight  
suspension  
frame  
that  
gives  
you  
an  
unbelievably  
smooth  
ride  
with  
more  
efficient  
utilization  
of  
pedal  
energy.*

# **SLING SHOT**

**A totally new concept in bicycle frame design. After 5 years of lab. testing and 3 years of BMX and Mt. Bike Racing, SlingShot with its unique design can now guarantee the following advantages over rigid frame bicycles.**

- 1. An Unbelievably smooth ride**
- 2. More efficient Utilization of pedal energy by the storage of energy in the coil springs.  
Example: When a tennis ball hits the center sweet spot of the racquet**
- 3. Light weight, but strong and durable**
- 4. Unique eyecatching design**
- 5. The first major workable change in frame design in one hundred years**
- 6. Has been stress tested 500,000 cycles**
- 7. Quickly adjustable to suit any weight rider simply by changing the coil springs**

Spring plate member is made from light weight Kevlar 49® which is the same type of material used in bullet-proof vests.

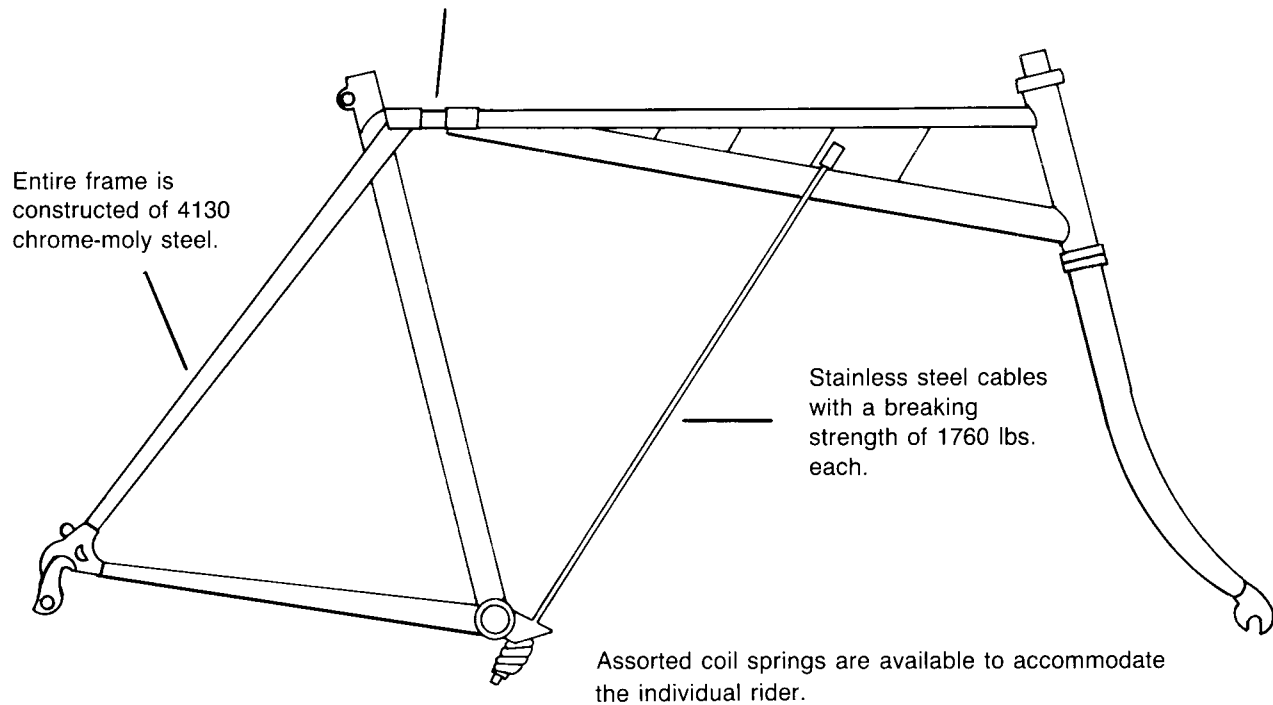

SEAT TUBE ANGLE	71°
HEAD TUBE ANGLE	70°
WHEEL BASE	42"
TOP TUBE LENGTH	22 <sup>3</sup> / <sub>4</sub> "
CHAIN STAY LENGTH	16 <sup>3</sup> / <sub>8</sub> "
B/B HEIGHT	11 <sup>3</sup> / <sub>4</sub> "
FRAME WEIGHT	6 <sup>1</sup> / <sub>2</sub> lbs (18" FRAME)



**GREENDALE BICYCLE CO.**  
41 COMMERCE S.W.  
GRAND RAPIDS, MICH. 49503  
(616) 451-9828

**"THE BIKE PEOPLE WITH THE UNRIGID IDEAS"**